

Barrier gate with integrated LED traffic lights and adjustable speed 0,8 to 6 sec. for the arms of 3-6 m length with 100% duty cycle for parking lots.



Description

- Cabinet made of welded sheet metal 2 mm thick protected by cathodolysis and structured paint in standard colors RAL 7024 and RAL 1028.
- Internal mechanical parts treated by galvanisation
- Front door with security lock, built –in LED Red/ Green traffic lights (optionally) and removable top cover
- Modern and innovative drive consisting of AC gear motor and transmission by crankshaft-rod device ensuring smooth movement
- Arm balancing by spring, 100% duty cycle
- Adjustable operation time from 0,8 to 6 sec. (depending on arm length)
- Automatic arm unlocking and rising in case of power failure
- Control unit with frequency inverter for speed setting and fluent acceleration and deceleration.



Specification

MODEL:	PARK15	PARK25	PARK35
Arm lenght:	3 m	5 m	6 m
Open/close time:	0,8 -1,5 sec.	2-3 sec.	4-6 sec.
Version:	left and right	left and right	left and right
Power supply:	230V / 50 Hz	230V / 50 Hz	230V / 50 Hz
Motor power:	180W	180W	180W
Working temperature:	-40°C - +75°C	-40°C- +75°C	-40°C- +75°C
Weight:	65 kg	65 kg	65 kg
Protection:	IP54	IP54	P54
MCBF:	7.000.000 cycles	7.000.000 cycles	7.000.000 cycles
Dimensions:	370 x 360 x 1120 mm	370 x 360 x 1120 mm	370 x 360 x 1120 mm
Duty cycle:	100%	100%	100%

Accessories

- GSM module with remote control
- Loop detector
- Photocells
- Push button
- Key switch fitted on cabinet
- Plastic folding fencing
- Protection rubber or red/green LED stripe on arm
- Folding arm

Left or right version

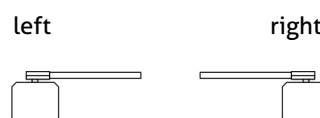

Dimensions

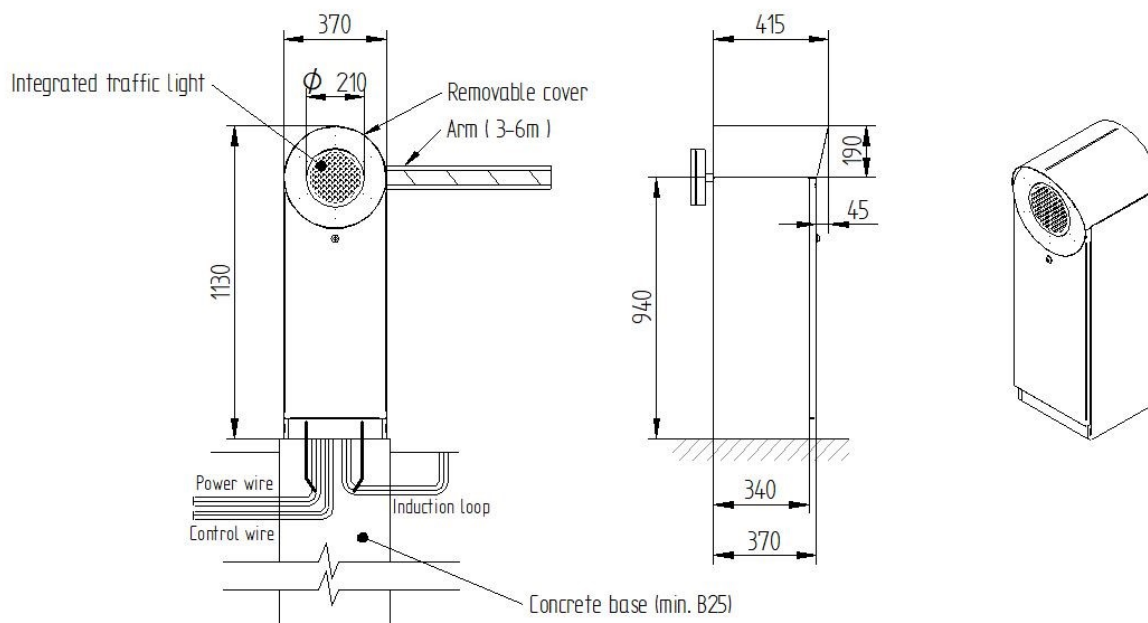

With constatnt view of adopting the latest technological development AS Parking reserves the right to amend the information above, and any time.