

PARK HS

Barrier gate with integrated LED traffic lights and adjustable speed 0,8 to 1,4 sec.
Innovative product of high performance, long life cycle and reasonable price.

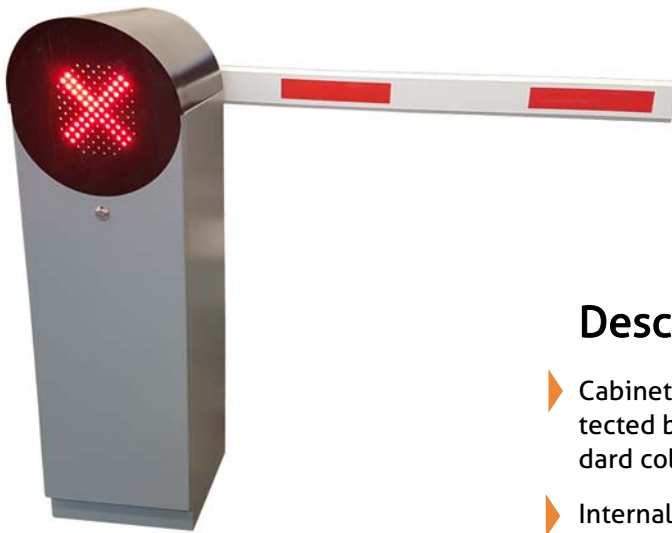

Description

- ▶ Cabinet made of welded sheet metal 2 mm thick protected by cataphoresis and structured paint in standard color RAL 7024
- ▶ Internal mechanical parts treated by galvanisation
- ▶ Front door with security lock, built -in LED Red/Green traffic lights
- ▶ Removable top cover
- ▶ Modern and innovative drive consisting of DC motor with gear and transmission by crankshaft-rod device ensuring smooth movement
- ▶ Arm balancing by spring
- ▶ Adjustable operation time from 0,8 to 1,4 sec.
- ▶ Automatic arm unlocking and rising in case of power failure
- ▶ Easy reversion of the arm (left or right version)
- ▶ Control unit enabling various commands and accessories connecting



Specification

MODEL:	PARK HS
Arm Length:	3 m
Operation time:	0,8 - 1,4 sec.
Version:	left and right
Power Supply:	230V / 50 Hz
Motor Power:	100W
Working Temperature:	-40°C až +75°C
Weight:	65 kg
Protection:	IP54
MCBF:	5.000.000 cycles
Dimensions:	330 x 1105 x 425 mm

Accessories

- remote control
- loop detector
- photocells
- push button
- key switch on cabinet
- plastic folding fencing
- protection rubber on arm
- folding arm

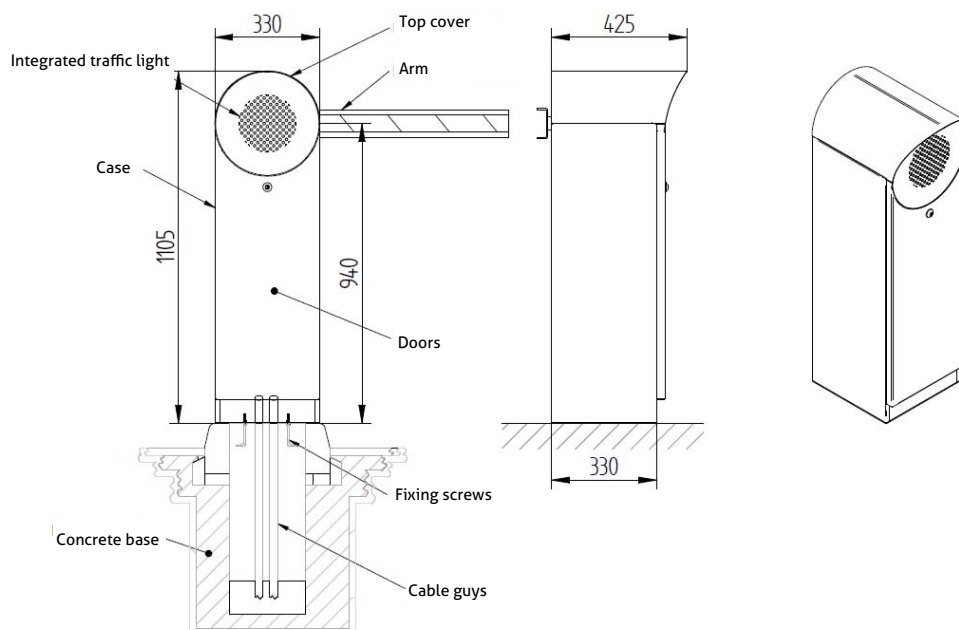

With a constant view of adopting the latest technological development AS Parking reserves the right to amend the information above, and any time.